

1 BOLLARD  
PLAN SCALE 1:50

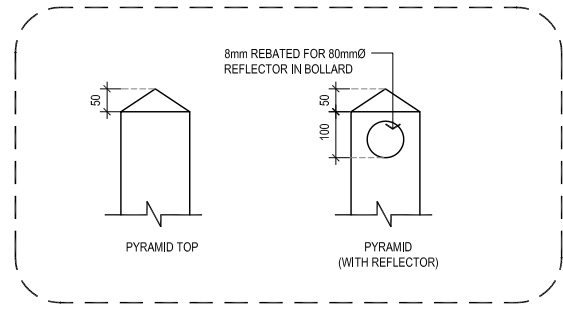

3 BOLLARD TOP FORM  
ELEVATION SCALE: NTS

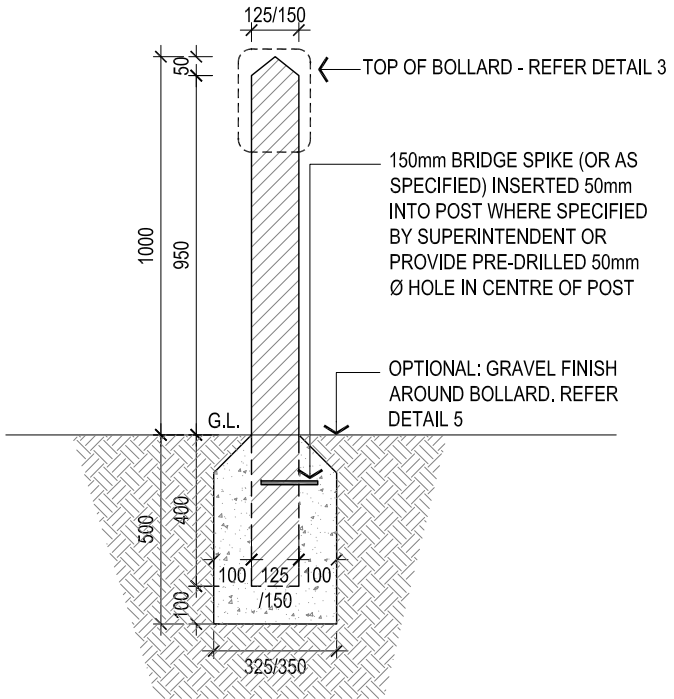

2 BOLLARD  
DETAIL SECTION SCALE 1:20

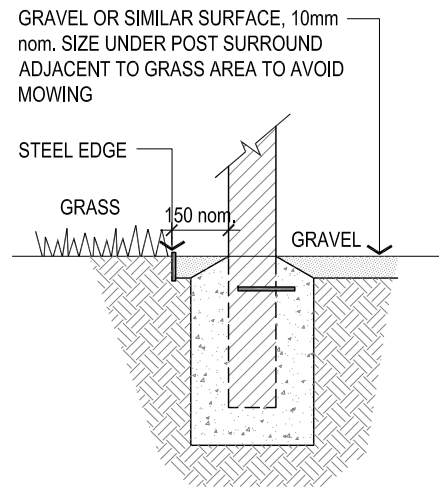

4 OPTIONAL - GRAVEL FINISHING  
SECTION SCALE 1:20

- NOTES:
- BOLLARD / POST WIDTHS:**
    - 125 x 125mm
    - 150 x 150mm
  - APPROVED BOLLARD MATERIALS:**
    - Solid Wood Plastic Composite
    - Solid Recycle Plastic
    - Dark color (dark grey/charcoal/black)



PO Box 119  
1079 Pascoe Vale Road  
Broadmeadows  
Victoria 3047  
Telephone  
(03) 9205 2200  
Facsimile  
(03) 9309 0109  
<http://www.hume.vic.gov.au>

ISSUE:	FOR USE
DRAWN:	S.ZHOU
UPDATED:	09 / 2020
SCALE:	AS SHOWN

STANDARD LANDSCAPE DRAWING

# BOLLARD

DRAWING NO.

SLD - 2.1