

PLAN

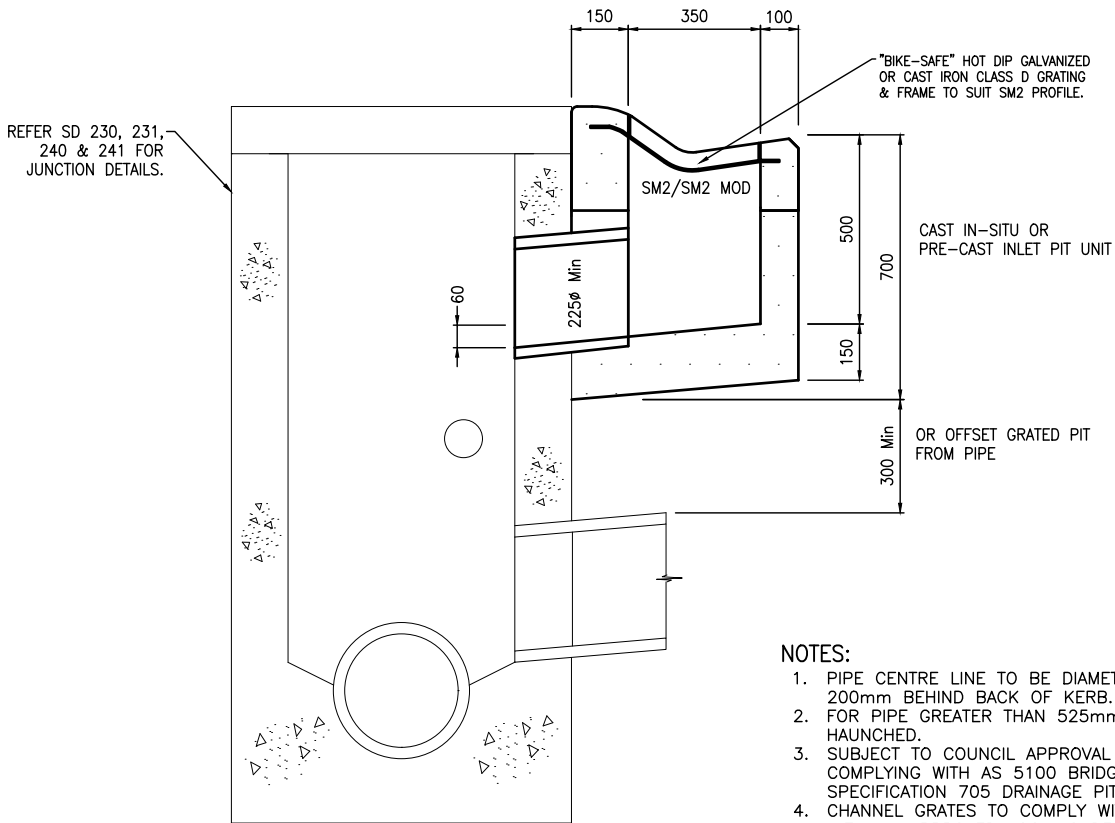

SECTION A - A

SINGLE GRATED SIDE ENTRY PIT  
SM2 KERB & CHANNEL  
N.T.S.

NOTES:

1. PIPE CENTRE LINE TO BE DIAMETER OF PIPE / 2 + 200mm BEHIND BACK OF KERB.
2. FOR PIPE GREATER THAN 525mm JUNCTION PIT TO BE HAUNCHED.
3. SUBJECT TO COUNCIL APPROVAL PRECAST PITS COMPLYING WITH AS 5100 BRIDGE DESIGN AND VICROADS SPECIFICATION 705 DRAINAGE PITS MAY BE USED.
4. CHANNEL GRATES TO COMPLY WITH AS 3996, BE FITTED WITH AN APPROVED LOCKING DEVICE AND HAVE A CLEAR OPENING OF 900mm X 350mm.
5. 225mm DIAMETER SEWER GRADE PVC PIPE WHEN GAP BETWEEN CATCH PIT AND JUNCTION PIT IS LESS THAN 300mm. 225mm DIAMETER REINFORCED CONCRETE PIPE WHEN GAP IS GREATER THAN 300mm.
6. SHAPE FLOOR OF PIT TO OUTLET & RENDER FLOOR AND WALLS TO CLASS 2 FINISH.
7. CONCRETE STRENGTH 32 MPa AT 28 DAYS.
8. NOT APPLICABLE TO MELBOURNE WATER CORPORATION DRAINAGE ASSETS. FOR MWC WORKS REFER TO MWC LAND DEVELOPMENT MANUAL

NOT TO SCALE

AMENDMENTS		
DATE	DETAILS	INITIALS
NOV 2022	INITIAL HUME STANDARDS UPDATE	T.D



SINGLE GRATED SIDE ENTRY PIT  
SM2 KERB & CHANNEL

VERSION: A

DRAWING NO:

SD215