

TYPICAL FOOTPATH CROSS SECTION

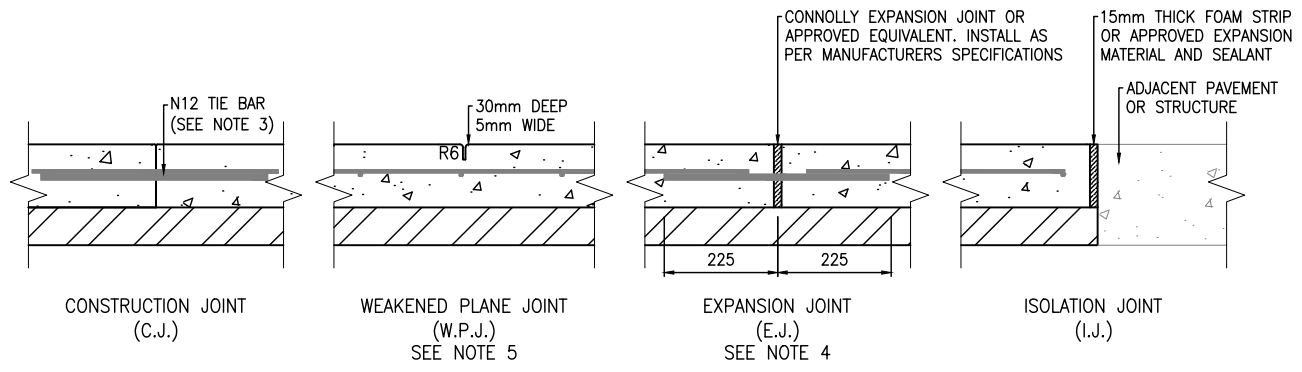

CONCRETE JOINT DETAILS

MAXIMUM FOOTPATH WIDTH (m)	MINIMUM NO. OF DOWELS AND TIE BARS
1.5	4
1.9	5
2.3	6
2.7	7

NOTES:

1. CONCRETE SHALL BE N32 (32MPa) FOR INDUSTRIAL, COMMERCIAL, COUNCIL RESERVE, PUBLIC OPEN SPACE AND COLOURED APPLICATIONS.
2. WHEN PATH IS BEING CONSTRUCTED ALONG THE FRONT OF PROPERTIES FOOTPATH TO BE FLUSH WITH THE TITLE BOUNDARY. IN THE PRESENCE OF A FENCE/RETAINING WALL, 10mm THICK ABELFLEX OR SIMILAR APPROVED PRODUCT TO BE INSTALLED AT FOOTPATH'S EDGE CLOSEST TO FENCE/RETAINING WALL.
3. TIE BARS (C.J.) TO BE INSTALLED AT MAXIMUM 400mm CENTRES COMMENCING BETWEEN 100mm AND 200mm FROM THE EDGE OF THE PATH.
4. EXPANSION JOINTS (E.J.) TO BE LOCATED BOTH SIDES OF VEHICLE CROSSINGS AND MAXIMUM 12m CENTRES.
5. WEAKENED PLANE JOINTS (W.P.J) OR CONTRACTION JOINTS TO BE LOCATED AT SPACINGS EQUAL TO THE WIDTH OF THE PATH AND MADE WITH A 'T' IRON OR CONCRETE SAW CUT.
6. CONCRETE TO BE LIGHT BROOM FINISH WITH EDGE AND JOINTS NEATLY TOOLED AFTER THE BROOM IS APPLIED.
7. ALL FINISHED SURFACES TO COMPLY WITH AS4586 SLIP RESISTANT CLASSIFICATION OF NEW PEDESTRIAN SURFACE MATERIAL.
8. FORMWORK TO BE MINIMUM 120mm DEEP. NO GAPS ALLOWED BETWEEN LENGTHS OF FORMWORK.
9. ALL DIMENSIONS IN MILLIMETERS UNLESS OTHERWISE STATED.
10. SINGLE PIECE OF REINFORCEMENT MESH TO MATCH REQUIRED WIDTH. NO OFFCUTS TO BE USED IN PLACE OF SINGLE WIDTH PIECE.
11. REINFORCEMENT MESH TO OVERLAP MINIMUM 200mm. ALL REINFORCEMENTS TO BE TIED.
12. REINFORCEMENT SHALL BE SUPPORTED USING PLASTIC CHAIRS.
13. ANY LINEAR FOOTPATH EQUAL TO OR GREATER THAN A WIDTH OF 3000mm MUST FOLLOW THE SHARED PATH STANDARD (SD325).

CONCRETE FOOTPATH CROSS SECTIONS AND JOINTS
NOT TO SCALE

NOT TO SCALE

AMENDMENTS				CONCRETE FOOTPATH CROSS SECTIONS AND JOINTS	
DATE	DETAILS	INITIALS		VERSION: A	DRAWING NO: SD320
NOV 2022	INITIAL HUME STANDARDS UPDATE	T.D			

