

1 DOUBLE LOCK BOX PLAN SCALE 1:5

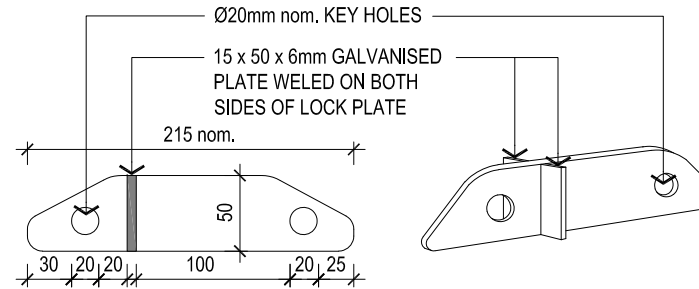

2 DOUBLE LOCK PLATE ELEVATION AND 3D VIEW SCALE 1:5

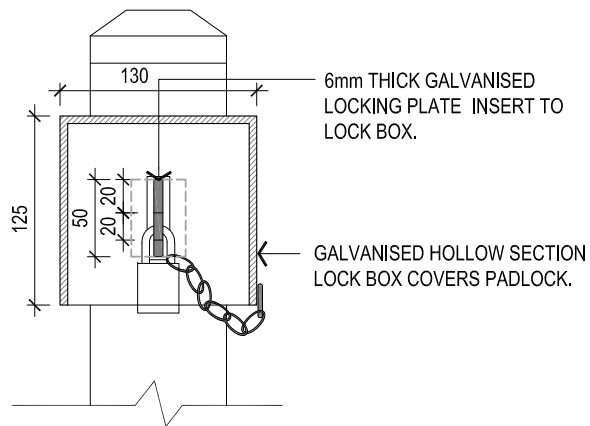

3 LOCK BOX FRONT SECTION SCALE 1:5

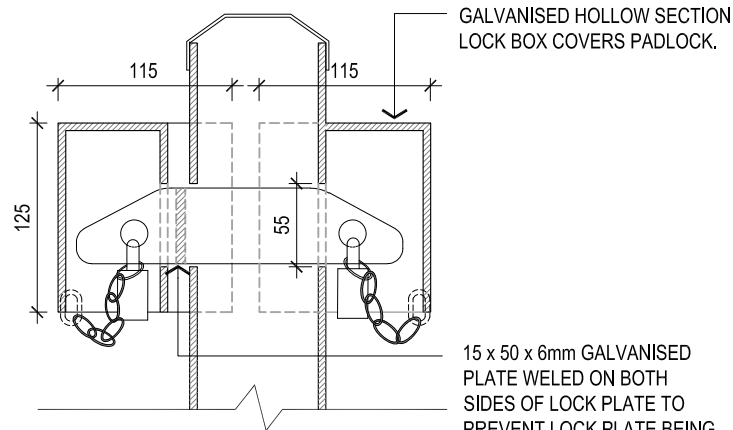

4 DOUBLE LOCK BOX SIDE SECTIONS SCALE 1:5

NOTE:

ALL MATERIALS ARE TO CONFORM TO THE FOLLOWING STANDARDS:

- COMPOSITE MATERIALS: *ASTM D7032-17 Standard Specification for Establishing Performance Ratings for Wood-Plastic Composite and Plastic Lumber Deck Boards, Stair Treads, Guards, and Handrails.*
- CONCRETE: *AS 1379-2007 Specification and supply of concrete.*
- GALVANISED FITTINGS: *AS/NZS 1214:2016 Hot-dip galvanised coatings on threaded fastener (ISO metric coarse thread series) (ISO 10684:2004, MOD)*
- GALVANISED MATERIALS: *AS/NZS 4680:2006 Hot-dip galvanised (zinc) coatings on fabricated ferrous articles.*
- STAINLESS STEEL: *AS 2837, 316 Grade.*